

LOADMASTER™

Electric Personnel and Burden Carrier

MODELS	B1-50
TYPE	E
SPEED (MAX MPH)	12
RANGE (MILES)	20
LOAD CAPACITY (lbs)	1,600
TOWING CAPACITY (lbs)	7,500
BED SIZE (W"xL")	44x63
VOLTAGE	36
TURNING RADIUS (INCHES)	110"



Tough and Dependable Product Solutions

Taylor-Dunn's Loadmaster™, built to carry 1,600 lbs. of load, is one of the most cost effective solutions to your material handling needs. Equipped with a 36 volt electric drive train, this vehicle is designed with one of the shortest turning radius in its class of vehicles. Designed with all steel unitized body, it provides years of reliable operation in rugged applications.

The Loadmaster's modular electrical system allows for ease of maintenance, thereby reducing your operating and maintenance costs. Loadmaster can be equipped with a ladder rack, tool boxes, tool cabinets, and a workbench and is an excellent choice for any maintenance application.

We at Taylor-Dunn and our team of world-wide dealers pride ourselves in providing after-sales support that far exceeds your expectations. Utilizing our regional sales support to configure the Loadmaster for your specific needs will provide you with the best solution for your application.

Features like seat interlock, high pedal disable, and mechanical or hydraulic brakes provide maximum safety during daily operations. All these features with factory equipped options to ensure highest quality standards, makes Loadmaster the best value for your utility applications.

With over 120,000 vehicles in service and over 45 years of experience, Taylor-Dunn products are the best way to go about your business.



TAYLOR-DUNN®
Commercial and Industrial Vehicles Since 1949

The best way to go about your business

PERSONNEL CARRIERS



Aristocrat



Roadmaster

BURDEN CARRIERS



Taylortruck



Loadmaster



Model B Series



Electruck



Maintenance Expediter



Cargomaster



Stockchaser

TOW TRACTORS



Towmaster



Mule



Pullmaster



Model E



Huskey

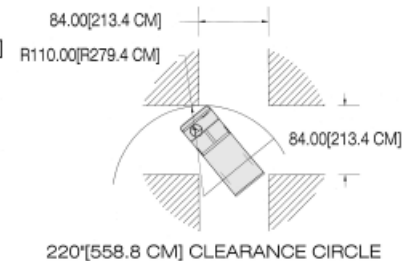
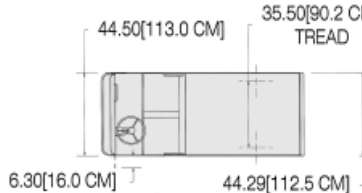
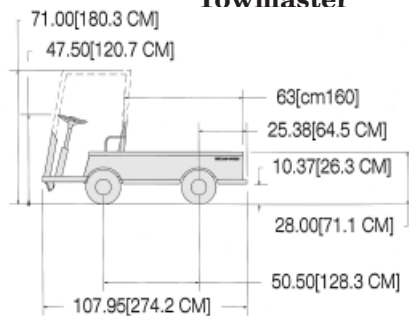

LOADMASTER STANDARD SPECIFICATIONS

- Product Line:** B1-50
Wheels: 4 wheels
Unit Weight: 1,214 lbs. (550 kg)
Load Capacity: 1,600 lbs.
Battery Type: Six 220 amp hr., 6 volt (lead acid)
System Voltage: 36 volts
Travel Distance (Unloaded): 20 miles
Energy Consumption: 264 watt/hr. per mile
Drive Axle: Direct drive, oil bath, 14.78:1 ratio
Motor: 36V@1,200 rpm, DC series, wound 6 hp
Speed (Unloaded): 12 mph
Gradeability: 15% empty, 5% loaded
Tires: 5.70 x 8 load range B pneumatic
Brakes: Two wheel mechanical rear drum w/hand operated parking brake
Steering: Automotive steering, 24:1
Frame: All-welded steel unitized body with heavy duty 16 gauge diamond plate



- Bumper:** Integrated heavy duty steel front
Suspension: Leaf springs front and rear
Color: Safety orange, traffic yellow
Seats: Individual driver and passenger cushions with full seat back
Controller: Solid state speed controller, 275 amp, 36 volt
Wiring: Modular harness design with weather protected connectors
Instrumentation: Battery status indicator, forward/reverse selector, key switch
Light Accessories: Brake light
Charger: 25 amp, 36 volt built in automatic charger
Charge Time: 8 hours for charge on batteries 80% discharged
Input Voltage: 110 volt/220 volt, 50 Hz/60 Hz
Charging Energy Requirements: 9.9 kw/hr @ 80% efficiency
Conformance Standards: Type E OSHA requirements 1910.178, ANSI B56-8 requirements

LOADMASTER™ OPTIONAL FEATURES

- Charger**
- Portable 25 amp charger or 40 amp charger
 - Built in 110V/220V 50 Hz.
- Accessories**
- Strobe light, amber - on pole, or top of cab
 - Headlights, directional signals
 - Reverse alarm, hour meter
 - Seat belts
- Deck**
- Stake sides, removable end gate, 14" high
 - Welding tank cutouts
 - Steel sides and end gates, fold down
 - Steel panel cargo box
- Battery Compartment**
- 244 a.h. batteries
 - Lift out

- Hitches**
- Hitch automatic coupling, trailer
 - Hitch pintle, trailer
 - Hitch, 1-7/8 ball and bracket
- Brakes**
- Front & rear wheel hydraulic
- Cab**
- Fiberglass cab & vinyl doors
 - Mirrors - left, right and rear
 - Windshield wiper
- Top Frames**
- Fiberglass or surrey top cover with tubular frame
- Frame**
- Smooth skin
- Color**
- White, or special paint color
 - Undercoating



TAYLOR-DUNN® CORPORATION
 Commercial and Industrial Vehicles Since 1949



METRO CROWN INTERNATIONAL
 A TAYLOR-DUNN® COMPANY



TIGER TRACTOR
 A TAYLOR-DUNN® COMPANY



2114 West Ball Road, Anaheim, CA 92804 • (714) 956-4040 • FAX (714) 956-3130
 Toll Free (800) 688-8680 Visit our website: www.taylor-dunn.com