



ERP-VF

Electric Powered Pneumatic Tire Trucks
3,000 · 4,000 lbs

Yale® ERP-VF electric trucks are available in 3000, 3500, and 4000 pound capacities designed for demanding applications that require clean, quiet-running, heavy-duty capability. These trucks are very maneuverable and offer plenty of power and high stacking ability, while also offering excellent ergonomics, reliability and maintenance ease.

AC Transistor Traction Control

AC technology offers smooth acceleration and directional changes, proportional regenerative braking and the Auto Deceleration System. The controller converts battery power to three phase AC power, and adjusts frequency and current to meet performance demands. Performance control settings and extensive diagnostics are accessible by technicians through the display or a PC. A Vehicle System Manager (VSM) utilizing CANbus technology monitors and controls key truck components and systems. The advanced thermal management system monitors component temperature and gradually adjusts performance to prevent damage to key components.

Controller Area Network (CANbus)

CANbus technology streamlines communications between truck systems through one main master controller, the Vehicle System Manager (VSM). Display, traction controller and pump controller are all controlled via the CANbus network. A connection point is provided for interface with a service PC.

Intellix VSM acts as a master truck controller, providing extensive monitoring and control of truck functions and systems. CANbus technology reduces wiring complexity and enables comprehensive communications between truck systems. The ergonomically positioned display transmits continual feedback to the operator and allows for communication of service codes.

Electrical System

The ERP-VF utilizes AC motor technology designed for exceptional performance. It uses a brushless induction motor for high starting torque and smooth rapid acceleration. A speed sensor built into the motor provides feedback to the control system, allowing motor speed and direction to be continuously monitored.

Dual Drive Motors

Left hand and right hand AC Drive motors are individually mounted for easy servicing. The outer end of each motor drives a wheel through a planetary gear transmission. The transmissions use helical gears with tooth geometry that is optimized to minimize gear noise. Each drive motor is individually controlled allowing for a “zero inside turning radius” scenario that provides excellent maneuverability.

Automatic Park Brake

The ERP-VF features an Automatic Park Brake that is applied by a spring when the truck is

stationary. Upon sensing a demand at the accelerator pedal, the brake is released and held “off” via an electrical solenoid within the park brake assembly. A manual override lever (located underneath the floor plate) is provided to disengage the brake if the truck has to be moved during service conditions in the absence of power on the truck.

Wet Disc Brakes

The brake system features standard oil cooled wet disc brakes which are mounted inside the drive unit assemblies, protecting them against dirt and moisture. These low pedal effort brakes require no adjustments and very little maintenance, yet provide long service life.

Power Assisted Braking

Power Assisted Braking is accomplished via the VSM. The VSM monitors brake line pressure. When this pressure exceeds a set threshold the VSM sends a signal to the traction controller to decelerate the traction motor proportionally to the brake pressure. The higher the brake pedal pressure being applied, the more quickly the truck will decelerate. The master cylinder is sealed and has an external fluid level sensor connected to an LCD icon/indicator on the instrument module. The standard Auto Deceleration System automatically slows the truck when the operator’s foot is removed from the accelerator pedal, extending brake life.

Voltage

36 or 48 volt systems are available to meet a variety of application requirements. A solid-state, return-to-neutral feature reduces the possibility of inadvertent truck movement. The truck will not start forward or rearward until the accelerator pedal has been depressed.

Operator Interface Display

The repositioned display is conveniently located in the upper right area of

(continued on back)



Truck shown with optional equipment.

BATTERY AND COMPARTMENT SPECIFICATIONS														
ERP030VF with 21.5" Long Compartment														
Battery Compartment Dimensions				Battery Dimensions and Specifications										
Compartment Type	Width	Length	Height	"X"		"Y"		"Z"	Volts	No. of Cells	Plates per Cell	Max Capacity 6 Hour Rate	Weight	
				Min	Max	Min	Max	Max					Min	Max
	in (mm)			in (mm)					amp hr (kwh)		lb (kg)			
With Auxiliary CTWT Platform	39 (990)	21.5 (546)	23.9 (607)	38.2 (970)	38.8 (986)	20 (508)	21.2 (539)	23.4 (594)	36	18	17	880 (30.6)	1700 (771)	2200 (998)
With Battery Rollers			25.4 (645)					24.9 (632)	48	24	13	660 (30.5)	1700 (771)	2200 (998)
Without Auxiliary CTWT Platform			26.7 (677)					26.1 (664)	48	24	13	660 (30.5)	2000 (907)	2500 (1134)

ERP035-040VF with 25.3" Long Compartment														
Battery Compartment Dimensions				Battery Dimensions and Specifications										
Compartment Type	Width	Length	Height	"X"		"Y"		"Z"	Volts	No. of Cells	Plates per Cell	Max Capacity 6 Hour Rate	Weight	
				Min	Max	Min	Max	Max					Min	Max
	in (mm)			in (mm)					amp hr (kwh)		lb (kg)			
With Auxiliary CTWT Platform	39 (990)	25.3 (642)	23.9 (607)	38.2 (970)	38.8 (986)	23.5 (597)	25 (635)	23.4 (594)	36	18	21	1100 (38.2)	2100 (953)	2400 (1089)
With Battery Rollers			25.4 (645)					24.9 (632)	48	24	15	770 (35.8)	2100 (953)	2400 (1089)
Without Auxiliary CTWT Platform			26.7 (677)					26.1 (664)	48	24	15	770 (35.8)	2500 (1134)	2800 (1270)

Battery Type: "EO" (Without Cover)
 Battery amp hr (kwh) capacity is max allowable per UL
 Commercially available lead acid batteries may not necessarily reach these max limits
 Battery Compartment Length is measured front to rear. Battery Compartment Width is measured across the truck

Battery Notes – Conventional Charging (Opt G26201)
 Battery Connector: 36 volt - Gray SB®350 (Anderson Power Products® P/N 6320G1 or equivalent)
 48 volt - Blue SB®350 (Anderson Power Products® P/N 6321G1 or equivalent)
 Battery Lead: Length 20" (508 mm), Position "B", 2/0 AWG

Battery Notes – Rapid / Fast Charging (Opt G26202)
 Battery Connector: Requires Dual Positive / Negative Cabling terminating in (2) Female EBC-320 DIN Connectors (Anderson Power Products® P/N A32503-0009 or equivalent)
 Each individual DIN connector to include 1 Red Conductor to (+) and 1 black conductor to (-)
 Battery Lead: Length 26" (660 mm), Position "B", Minimum Cable Size 3/0 AWG

ERP030-040VF MAST DIMENSIONS					
Maximum Fork Height (TOF) +	Overall Lowered Ht.	Overall Extended Height w/Load -Backrest	Overall Extended Height w/o Load Backrest	Free-Lift (TOF) w/ Load Backrest	Free-Lift (TOF) w/o Load Backrest
in. (mm)	in. (mm)	in. (mm)	in. (mm)	in. (mm)	in. (mm)
2-STAGE LIMITED FREE-LIFT (LFL) MAST					
119 (2032)	78 (1980)	168 (4262)	142 (3606)	5 (140)	5 (140)
127 (3232)	82 (2080)	176 (4462)	150 (3806)	5 (140)	5 (140)
2-STAGE FULL FREE-LIFT (FFL) MAST					
118 (3018)	78 (1980)	168 (4262)	143 (3613)	29 (750)	55 (1405)
126 (3218)	82 (2080)	176 (4462)	151 (3813)	33 (850)	59 (1505)
138 (3518)	88 (2230)	188 (4768)	162 (4113)	39 (1000)	65 (1655)
3-STAGE FULL FREE-LIFT (FFL) MAST					
175 (4450)	78 (1980)	224 (5025)	198 (5025)	29 (750)	55 (1405)
187 (4750)	82 (2080)	236 (5325)	210 (5325)	33 (850)	59 (1505)
192 (4900)	84 (2130)	238 (5375)	212 (5375)	35 (900)	61 (1555)
198 (5050)	88 (2230)	248 (5625)	222 (5625)	39 (1000)	65 (1655)
216 (5500)	94 (2380)	265 (6075)	240 (6075)	45 (1150)	71 (1805)
4-STAGE FULL FREE-LIFT (FFL) MAST					
241 (6121)	84 (2121)	291 (7380)	265 (6721)	34 (873)	59 (1511)
259 (6578)	90 (2273)	309 (7837)	283 (7179)	40 (1025)	65 (1663)

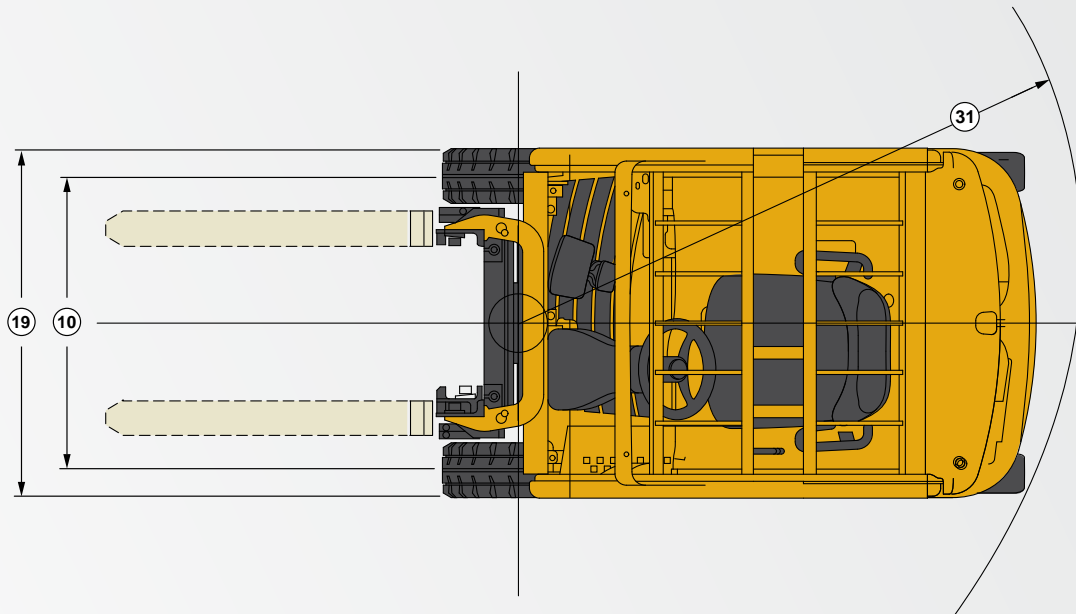
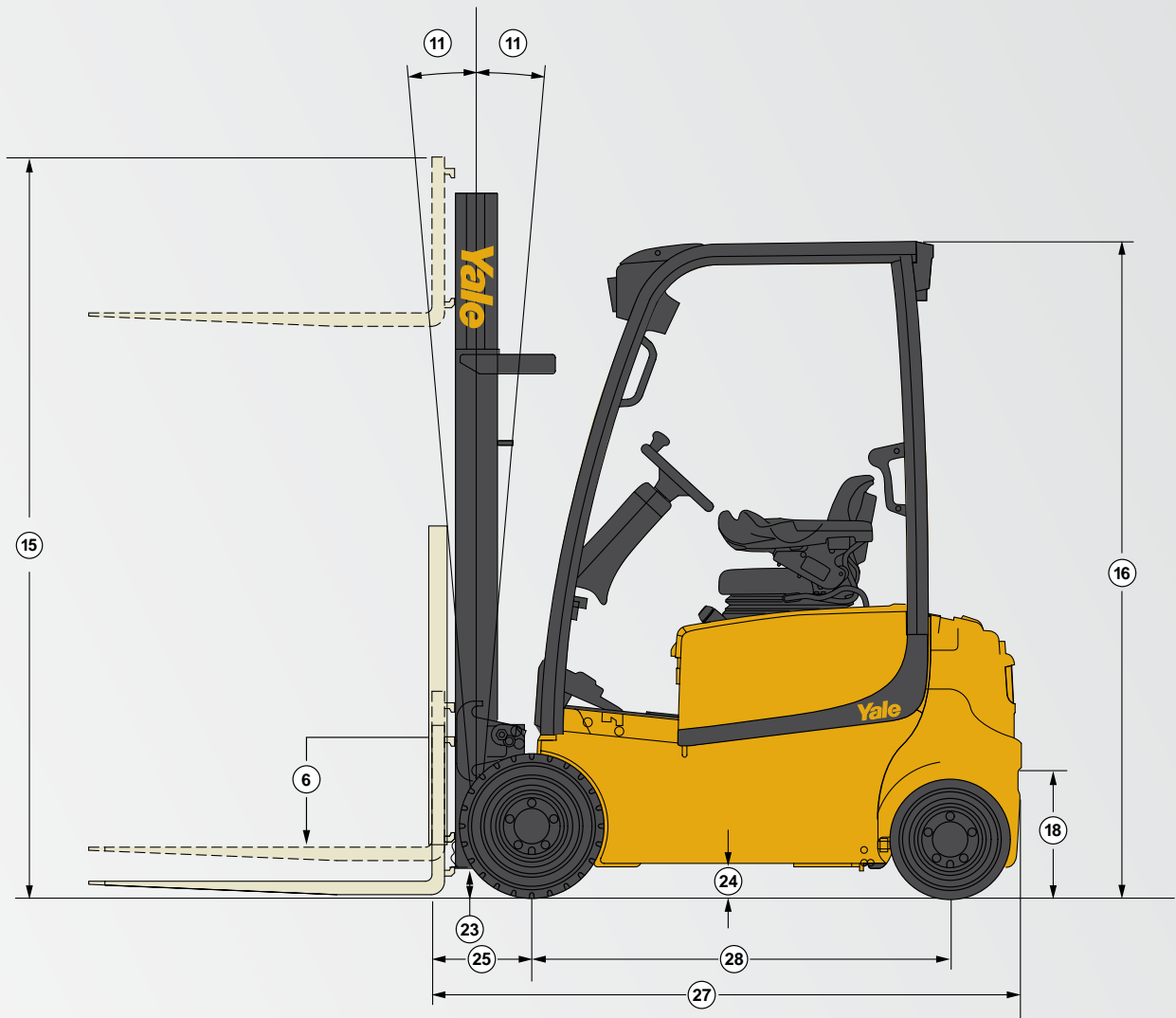

GENERAL	1	Manufacturer			Yale®	
	2	Model Designation			ERPO30VF	
	3	Power			Electric	
	4	Operation			Sit	
	5	Rated Capacity		lb. (kg)	3000 (1361)	
	6	Load Center		in. (mm)	24 (610)	
TIRES	7	Tire Type - Cushion, Solid, Pneumatic, etc. (Drive/Steer)			Pneumatic Shaped Solid / Pneumatic Shaped Solid	
	8	Tire Size (Drive/Steer)		in.	18 x 7-8 / 140 / 55-9	
	9	Wheels - Number X=Driven (Drive/Steer)			2X / 2	
	10	Tread Ctr. of Tires (Drive/Steer)		in. (mm)	35 / 35.4 (889 / 898)	
DIMENSIONS	11	Mast Tilt	Std Opt Opt	degrees	5F / 5B 10F / 5B 5F / 4B	
	12	Mast - Lowered Height	Std Mast	in. (mm)	78 (1980)	
	13	Free Lift - Top of Fork	Std 2 Stg Limited Free Lift Mast	in. (mm)	5 (140)	
			Opt 2 Stg Full Free Lift Mast with/without LBR	in. (mm)	29 / 55 (750 / 1405)	
	14	Lift Height - Top of Fork	Std 2 Stg Limited Free Lift Mast	in. (mm)	119 (3032)	
	15	Mast - Extended Height	Std Mast with/without LBR	in. (mm)	168 / 142 (4262 / 3606)	
	16	Overhead Guard Height	Std/Flat Plate/Drive in Rack	in. (mm)	81.5 / 77.9 / 81.5 (2070 / 1979 / 2070)	
	17	SIP to Bottom Std OHG	Nominal Std/Susp/Swivel	in. (mm)	38.9 / 39.2 / 38.7 (989 / 997 / 985)	
	18	Tow Pin Height	Vertical Center of Pin	in. (mm)	14.1 (360)	
	19	Overall Width		in. (mm)	41.7 (1060)	
	20	Forks	Thickness x Width x Length	in. (mm)	1.6 x 3.9 x 42 (40 x 100 x 1067)	
	21	Standard Carriage Width		in. (mm)	38.5 (977)	
	22	Floor to Top of Battery Rollers		in. (mm)	7 (178)	
	23	Ground Clearance	Lowest Point (NL/RL)	in. (mm)	2.8 / 2.8 (70 / 70)	
	24	Ground Clearance	Center of Truck (NL/RL)	in. (mm)	3.7 / 3.5 (95 / 90)	
	25	Load Distance	Center of Wheel to Face of Forks	in. (mm)	12.6 (321)	
	26	Battery Compartment	Height Std/Battery Rollers/Tall	in. (mm)	23.9 / 25.4 / 26.7 (607 / 645 / 677)	
			Width	in. (mm)	39 (990)	
			Length	in. (mm)	21.5 (546)	
	27	Length to Face of Forks	Chassis Length	in. (mm)	74.1 (1881)	
	28	Wheelbase		in. (mm)	52.6 (1335)	
29	Right Angle Stack		in. (mm)	122.0 (3100)		
30	Equal Aisle	90° Intersecting Aisle	in. (mm)	70 (1779)		
31	Outside Turning Radius		in. (mm)	61.4 (1560)		
WT.	32	Truck Weight	Without Battery (NL)	lb. (kg)	5140 (2331)	
	33	Axle Loading - Drive	Static with Max. Wt. Battery (NL/RL)	lb. (kg)	3641 / 8733 (1652 / 3961)	
	34	Axle Loading - Steer	Static with Max. Wt. Battery (NL/RL)	lb. (kg)	3695 / 1603 (1676 / 727)	
PERFORMANCE	35	Voltage			36	48
	36	Travel Speed	Extended Shift OFF (NL/RL)	mph (km/h)	9.8 / 9.8 (15.7 / 15.7)	
			Extended Shift ON (NL/RL)	mph (km/h)	8.7 / 8.7 (14.0 / 14.0)	
	37	Lift Speed	Std 2 Stg LFL Mast (NL/RL)	ft/min (m/sec)	128 / 77 (0.65 / 0.39)	
			Opt 2 Stg FFL Mast (NL/RL)	ft/min (m/sec)	114 / 75 (0.58 / 0.38)	
			Opt 3 Stg FFL Mast (NL/RL)	ft/min (m/sec)	114 / 75 (0.58 / 0.38)	
			Opt 4 Stg FFL Mast (NL/RL)	ft/min (m/sec)	120 / 77 (0.61 / 0.39)	
	38	Lower Speed	Std 2 Stg LFL Mast (NL/RL)	ft/min (m/sec)	93 / 100 (0.47 / 0.51)	
			Opt 2 Stg FFL Mast (NL/RL)	ft/min (m/sec)	77 / 91 (0.39 / 0.46)	
			Opt 3 Stg FFL Mast (NL/RL)	ft/min (m/sec)	81 / 91 (0.41 / 0.46)	
			Opt 4 Stg FFL Mast (NL/RL)	ft/min (m/sec)	94 / 98 (0.48 / 0.50)	
	39	Gradability	5 Minute Rating (NL/RL)	%	38.4 / 26.5	
			60 Minute Rating (NL/RL)	%	6.0 / 4.4	
	40	Drawbar Pull	5 Minute Rating (NL/RL)	lbf	2719 / 2714 (12096 / 12072)	
			60 Minute Rating (NL/RL)	lbf	458 / 462 (2038 / 2054)	
41	Brake	Method of Control (Service/Parking)		Hydraulic / Mechanical		
		Method of Operation (Service/Parking)		Foot / Automatic		
ELECTRIC	42	Battery	Type		Lead Acid	
	43	Traction Motors (Dual)	60 Minute Rating (Each)	hp (kW)	6.4 (4.8)	
	44	Pump Motor	15 Minute Rating	hp (kW)	16.1 (12.0)	
	45	Traction Motors	Type/Control Method		AC / Transistor	
	46	Pump Motor	Type/Control Method		AC / Transistor	
47	Number of Speeds	Traction/Pump		Infinitely Variable / Infinitely Variable		
OTHER	48	Step Height		in. (mm)	19.1 (484)	
	49	Floor Height	Lowest Point	in. (mm)	21.9 (557)	
	50	Attachment Relief Pressure (Mech Levers/Mini Levers)		psi (bar)	2611 / 2248 (180 / 155)	
	51	Auxiliary Oil Flow	3rd and 4th Function	gal/min (l/min)	5.3 / 10.6 (20 / 40)	
	52	Sound Level	Measured per ANSI B56.11.5	dB (A)	69	

Yale®	Yale®	1	GENERAL
ERPO35VF	ERPO40VF	2	
Electric	Electric	3	
Sit	Sit	4	
3500 (1588)	4000 (1814)	5	
24 (610)	24 (610)	6	
Pneumatic Shaped Solid / Pneumatic Shaped Solid	Pneumatic Shaped Solid / Pneumatic Shaped Solid	7	TIRES
18 x 7-8 / 140 / 55-9	200 / 50-10 / 140 / 55-9	8	
2X / 2	2X / 2	9	
35 / 35.4 (889 / 898)	35.7 / 35.4 (908 / 898)	10	DIMENSIONS
5F / 5B 10F / 5B 5F / 4B	5F / 5B 10F / 5B 5F / 4B	11	
78 (1980)	78 (1980)	12	
5 (140)	5 (140)	13	
29 / 55 (750 / 1405)	29 / 55 (750 / 1405)	14	
119 (3032)	119 (3032)	15	
168 / 142 (4262 / 3606)	168 / 142 (4262 / 3606)	16	
81.5 / 77.9 / 81.5 (2070 / 1979 / 2070)	81.5 / 77.9 / 81.5 (2070 / 1979 / 2070)	17	
38.9 / 39.2 / 38.7 (989 / 997 / 985)	38.9 / 39.2 / 38.7 (989 / 997 / 985)	18	
14.1 (360)	14.1 (360)	19	
41.7 (1060)	43.9 (1116)	20	
1.6 x 3.9 x 42 (40 x 100 x 1067)	1.6 x 3.9 x 42 (40 x 100 x 1067)	21	
38.5 (977)	38.5 (977)	22	
7 (178)	7 (178)	23	
2.8 / 2.8 (70 / 70)	2.8 / 2.8 (70 / 70)	24	
3.7 / 3.5 (95 / 90)	3.7 / 3.5 (95 / 90)	25	
12.6 (321)	12.6 (321)	26	
23.9 / 25.4 / 26.7 (607 / 645 / 677)	23.9 / 25.4 / 26.7 (607 / 645 / 677)	27	
39 (990)	39 (990)	28	
25.3 (642)	25.3 (642)	29	
77.8 (1975)	77.7 (1975)	30	
56.3 (1431)	56.3 (1431)	31	
125.8 (3196)	125.8 (3196)	32	
71.3 (1812)	72.2 (1835)	33	
65.2 (1656)	65.2 (1656)	34	
5270 (2390)	5310 (2409)	35	WT.
3795 / 9573 (1721 / 4342)	3839 / 10443 (1741 / 4737)	36	
3866 / 1588 (1754 / 720)	3866 / 1262 (1754 / 572)	37	
36	48	36	PERFORMANCE
9.8 / 9.8 (15.7 / 15.7)	9.8 / 9.8 (15.7 / 15.7)	37	
8.7 / 8.7 (14.0 / 14.0)	8.7 / 8.7 (14.0 / 14.0)	38	
128 / 71 (0.65 / 0.36)	134 / 94 (0.68 / 0.48)	39	
114 / 75 (0.58 / 0.38)	120 / 85 (0.61 / 0.43)	40	
114 / 75 (0.58 / 0.38)	120 / 85 (0.61 / 0.43)	41	
120 / 77 (0.61 / 0.39)	126 / 89 (0.64 / 0.45)	42	
93 / 100 (0.47 / 0.51)	93 / 100 (0.47 / 0.51)	43	
77 / 91 (0.39 / 0.46)	77 / 93 (0.39 / 0.47)	44	
81 / 91 (0.41 / 0.46)	81 / 93 (0.41 / 0.47)	45	
94 / 98 (0.48 / 0.50)	94 / 98 (0.48 / 0.50)	46	
36.2 / 24.3	35.0 / 25.0	47	
5.7 / 4.0	9.2 / 5.9	48	
2719 / 2712 (12093 / 12065)	2479 / 2417 (11027 / 10751)	49	
457 / 460 (2035 / 2047)	733 / 672 (3261 / 2989)	50	
457 / 460 (2034 / 2044)	733 / 663 (3261 / 2949)	51	
Hydraulic / Mechanical	Hydraulic / Mechanical	52	ELECTRIC
Foot / Automatic	Foot / Automatic	53	
Lead Acid	Lead Acid	54	
6.4 (4.8)	6.7 (5.0)	55	
16.1 (12.0)	16.1 (12.0)	56	
AC / Transistor	AC / Transistor	57	
AC / Transistor	AC / Transistor	58	
Infinitely Variable / Infinitely Variable	Infinitely Variable / Infinitely Variable	59	OTHER
19.1 (484)	19.1 (484)	60	
21.9 (557)	21.9 (557)	61	
2611 / 2248 (180 / 155)	2611 / 2248 (180 / 155)	62	
5.3 / 10.6 (20 / 40)	5.3 / 10.6 (20 / 40)	63	
69	69	64	
69	69	65	

the operator's compartment. The display includes an hour meter, LCD display for status codes and descriptions, battery discharge indicator with lift interrupt, all LCD icons/indicators for brake fluid, seat belt indicator, performance mode indicator, and parking brake indicator. The display also permits access for service technicians to adjust performance control settings, allowing the truck to be customized to meet customer applications. Additionally, extensive diagnostics allow service technicians to quickly troubleshoot problems. Operator selectable performance modes are standard. Options for operator passwords and a pre-shift operator checklist are also available.

Foot Directional Control Pedal (FDC)

The optional foot directional control pedal is a highly productive directional/accelerator pedal. One pedal allows the operator to change direction and acceleration reducing operator movement and resulting in increased productivity.

Hydraulic Components

A transistor control hydraulic system is powered by a brushless, AC induction motor with wet coupling. The motor and pump are mounted on rubber isolators for reduced noise and vibration. A combination of flexible wire-braid hoses and steel tubing is used to simplify the hydraulic plumbing. These hydraulic lines are carefully routed and held in place to reduce possible damage. A 10-Micron full flow hydraulic filter located in the return line protects the hydraulic system from contaminants and helps provide long life. A by-pass relief valve permits oil flow in the event of the filter clogging.

Hydrostatic Power Steering

Hydrostatic power steering is standard and the all-hydraulic design gives precise, reliable control while eliminating mechanical linkages and road shocks at the steering wheel. An infinitely adjustable tilt steering column provides excellent operator comfort and visibility.

Steering Axle

The steering axle is a one-piece ductile iron casting mounted on elastic cushions that reduce shock and provide a softer ride. The Continuous Stability System enhances truck stability in a simple, maintenance free design, without compromising uneven surface travel. "Zero Turn Radius" steer axle design allows for increased maneuverability.

Masts/Carriage/Forks/Load Backrest Extension

Yale simplex, duplex, triplex, and quad masts provide excellent visibility. The mast features flush face design with geometrically matched, angled load rollers, which are canted, yet provide full-face roller contact. A single lift chain provides

increased visibility. The mast front rail flange angle coupled with the inverted "J" inner channel and 3-degree mast rollers significantly reduces channel web milling and roller wear. Trunnion mounts have replaceable bushings for longer life. The standard Class II carriage features pre-lubed and sealed full radius, angled load rollers that resist forward, backward, and lateral forces. Forks are "upset forged" from a single piece of high strength steel to give strength and added thickness for wear. A 48" load backrest extension is standard. An optional integral sidsifter is available on the ERP-VF. Various internal and external auxiliary function hose groups are available.

Frame

The frame is a unitized construction, stress tested for durability. An integral step on both sides of the truck is provided for easy entry and exit. The truck has a two-piece floor plate that can be easily lifted out for service access. An easily removable counterweight top cover gives easy access to components. A stamped steel, gas spring-assisted hood allows easy changing of the battery.

Additional Features

Additional features on the ERP-VF include an overhead guard, 42" forks, non-suspension seat, seat belt and an operator sensing switch. An infinitely adjustable tilt steering column, rubber floor mat, and electric horn are also standard.

Options

- Accutouch e-hydraulics Mini-levers
- Foot Directional Control Pedal
- Return to set tilt
- Telescoping Steering Column with Tilt Memory
- Full suspension seats (with and without swivel)
- Red (Hi-VIS) ELR non-cinch seat belt
- Battery rollers
- Overhead guard mounted headlights
- LED and Halogen work light packages
- LED Dome/reading light
- Brake and Tail light packages
- 10° forward tilt
- Integral sidsifter
- Audible Alarm – Reverse Operation
- Light – Amber strobe
- Rubber cushion drive tires and steer tires
- Type "EE" UL construction
- Dual Rear View Mirrors
- Panoramic Rear View Mirrors
- Fire Extinguisher
- 48 Volt
- Rapid/Fast Charging Configuration
- Drive-in rack overhead guard
- Cooler/Freezer Packages
- Subzero Freezer Package



YALE MATERIALS HANDLING CORPORATION

P.O. Box 7367, Greenville, NC 27835-7367

www.yale.com

Yale is a Registered Trademark and  is a Registered Copyright.
©Yale Material Handling Corporation 2013. All Rights Reserved.

Manufactured in our own ISO 9001 and 14001 Registered Facilities

2354-2B 3/2013 All trucks shown with optional equipment.

Truck performance may be affected by the condition of the vehicle, how it is equipped and the application. Consult your Yale® Industrial Truck Dealer if any of the information shown is critical to your application. Specifications are subject to change without notice.

This truck meets all design specifications of ANSI B56.1 Safety Standard for Powered Industrial Trucks at the time of manufacture. Classified by Underwriters' Laboratories, Inc. as to fire hazard only.

The Yale® products included in this document may be covered by US patent 6,684,148 and other patents pending.

Yale, the Yale Logo, Veractor® VX and Yale Global Hi-Vis™ Mast are trademarks or registered trademarks of Yale Materials Handling Corporation in the United States and other countries.